

Ball Valve, Plastic

Construction

The GEMÜ 723 motorized 2/2 or 3/2-way plastic ball valve has a low maintenance electric actuator with a powerful DC motor. The rugged reduction gear in the motor, consisting of a threaded spindle with a lever, provides the rotation through 90°. The housing is made of plastic. An optical position indicator and a manual override are standard.

Features

- Suitable for inert and corrosive* liquid and gaseous media
- The union ended body enables the valve to be installed in the pipeline without additional components.

Advantages

- Adjustable end positions by means of microswitches
- Emergency power supply with 24V DC types by means of emergency power supply module GEMÜ 1570 (not with actuator version 2070)
- Opening and closing behaviour is independent of the operating pressure
- Optional accessories for the 2/2-way ball valve:
 - Mounting plate DN 15 - DN 25 article no. 88290237
 - Mounting plate DN 32 - DN 50 article no. 88290238Please order separately.

*see information on working medium on page 2

Actuator with mounting kit, 2/2-way version

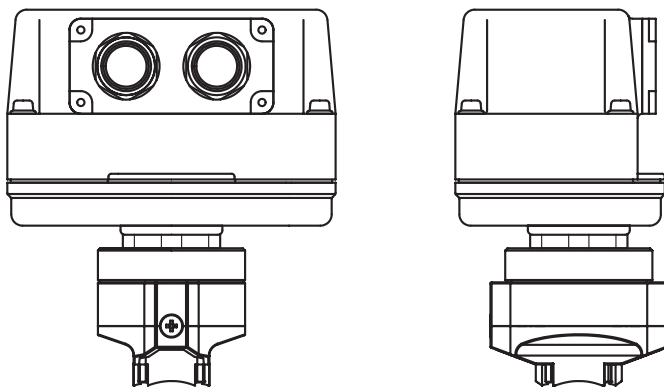

Actuator with mounting kit, 3/2-way version

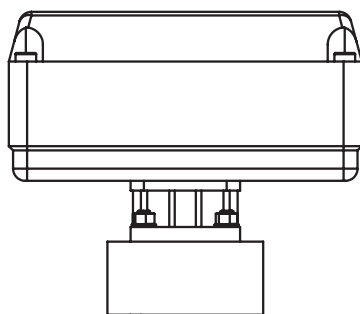

For actuator dimensions see page 6



Technical data

Working medium

Corrosive, inert, gaseous and liquid media which have no negative impact on the physical and chemical properties of the body and seal material.

Max. operating pressure 10 bar*
(for water and non-hazardous media to which the body material is resistant)

Maximum permissible temperature of working medium:

Tightness: EN 12266-1 / leakage rate A

* See data sheet "Technical Information on Plastic Materials"

Protection class to EN 60529

IP 65

Manual override

With Allen key SW3
for actuator version 1006, 1015

With hand crank
for actuator version 2006, 2015, 2070

Travel

Nominal travel 90°

Max. travel 93°

Actuator version 1006, 1015, 2006, 2015

Setting range limit switch Min. -2 to 12°

Setting range limit switch Max. 76 to 91°

Actuator version 2070

Setting range limit switch Min. 0 to 20°

Setting range limit switch Max. 70 to 93°

Permissible temperatures

Ambient temperature -10 to +60° C

Storage temperature -20 to +60° C

Nominal size	Kv value [m ³ /h]		Weight [g]				
	Body type D	Body type M	PVC-U		PP		PVDF
DN	Body type D	Body type M	Body type D	Body type M	Body type D	Body type M	Body type D
15	200	dependent on ball configuration and port position	1320	1295	1260	1225	1370
20	385		1455	1435	1355	1320	1520
25	770		1685	1630	1545	2470	1785
32	1100		2095	2075	1880	1815	2235
40	1750		2370	2510	2120	2080	2570
50	3400		3130	3305	2695	2620	3500

Electrical connection

Actuator version	1006, 1015, 2006, 2015		2070			
Supply voltages	12V / 24V	100 - 250V	24V, 120V, 230V			
Functional module	A0,AE		A0,AE, AP	00,0E, 0P	E1	E2
Control input voltage	Motor voltage	20 - 250V AC/DC	24 - 250V AC/DC	Motor voltage	0 ... 10V	-
Control input current	-	typ. 1 mA	typ. 1 mA			0/4 ... 20 mA
Rating	Continuously rated	rated 40%	Continuously rated			
Connection	Cable connection PG 13.5	Hirschmann plug type N6RFFS11	Flange plug Binder 692/693			
Cable diameter	7.5 to 12.5 mm	7 to 9 mm	max. 8 mm			
Max. cross section of wire	1.5 mm ²	1.5 mm ²	0.75 mm ²			
Recommended connection cable	5x1 mm ² Ölflex®	1 connector (standard): 7x1 mm ² Ölflex®	7x1 mm ² Ölflex®			
Overload protection	Motor protective system by customer	Integrated stall and overload protection plus excess current release T 1A 5x20 mm	Motor protective system by customer			

Actuator materials

Actuator version	1006, 1015	2006, 2015	2070
Housing base	PP (30% glass reinforced)	PP (30% glass reinforced)	ABS
Housing cover	PPO (10% glass reinforced)	PP (30% glass reinforced)	ABS
Optical position indicator	PPR natural	PPR natural	PPR natural

Technical data

Power consumption [W]

Voltage/ Frequency	B1 12V DC		C1 24V DC		B4 12V AC		C4 24V AC		G4 120V AC		L4 230V AC		O4 100-250V DC	
	A0,AE,AP E1,E2	00,0E 0P	A0,AE,AP E1,E2	00,0E 0P	A0,AE,AP E1,E2	00,0E 0P	A0,AE,AP E1,E2	00,0E 0P	A0,AE,AP E1,E2	00,0E 0P	A0,AE,AP E1,E2	00,0E 0P	A0,AE,AP E1,E2	00,0E 0P
Actuator version	1006	24	-	24	-	24	-	24	-	-	-	-	-	-
	1015	24	-	24	-	-	-	-	-	-	-	-	-	-
	2006	-	-	-	-	-	-	-	-	-	-	-	30	-
	2015	-	-	-	-	24	-	24	-	-	105	-	-	30
	2070	-	-	96	63	-	-	-	63	160	90	161	-	-

Correlation Actuator version (torque) / Voltage-frequency

Voltage/Frequency	B1 12V DC		C1 24V DC		B4 12V AC		C4 24V AC		G4 120V AC		L4 230V AC		O4 100-250V DC	
Actuator version	1006 (6 Nm)	X	X	X	X	-	-	-	-	-	-	-	-	-
	2006 (6 Nm)	-	-	-	-	-	-	-	-	-	-	-	X	-
	1015 (15 Nm)	X	X	-	-	-	-	-	-	-	-	-	-	-
	2015 (15 Nm)	-	-	X	X	-	-	-	-	-	-	-	-	X
	2070 (70 Nm)	-	X	-	X	-	-	-	X	X	X	X	-	-

Correlation Actuator version (torque) / Functional module

Functional module	A0	AE	AP	E2	E1	00	0E	0P
	Actuator version							
1006 (6 Nm)	X	X	-	-	-	-	-	-
2006 (6 Nm)	X	X	-	-	-	-	-	-
1015 (15 Nm)	X	X	-	-	-	-	-	-
2015 (15 Nm)	X	X	-	-	-	-	-	-
2070 (70 Nm)	X	X	X	X	X	X	X	X

Correlation Actuator version (torque) / Nominal size

Nominal size	DN 15	DN 20	DN 25	DN 32	DN 40	DN 50
	Actuator version					
1006 (6 Nm)	X	X	X	-	-	-
2006 (6 Nm)	X	X	X	-	-	-
1015 (15 Nm)	X	X	X	X	X	-
2015 (15 Nm)	X	X	X	X	X	-
2070 (70 Nm)	-	-	-	-	-	X

Inserts for connections other than standard solvent cement/welded sockets*

DN	Butt weld spigots		Threaded sockets		
	PE	PP	Threads	PVC-U	PP
15	CVDE 020	CVDM 020	G 1/2	POFV 012	POFM 012
20	CVDE 025	CVDM 025	G 3/4	POFV 034	POFM 034
25	CVDE 032	CVDM 032	G 1	POFV 100	POFM 100
32	CVDE 040	CVDM 040	G 1 1/4	POFV 114	POFM 114
40	CVDE 050	CVDM 050	G 1 1/2	POFV 112	POFM 112
50	CVDE 063	CVDM 063	G 2	POFV 200	POFM 200

* Please order separately

Order data

Body configuration	Code
Straight through body (2/2-way)	D
Multi-port body (3/2-way)	M

Connection	Code
Solvent cement/welded sockets (DIN)	2
Further connections by using inserts see table page 3	

Valve body material	Code
PVC-U	1
PP, reinforced	5
PVDF (only seal material code 4)	20

Seal material	Code
FPM	4
EPDM	14

Voltage/Frequency	Code
12V DC (only actuator version 1006, 1015)	B1
12V 50/60 Hz (only actuator version 1006, 2015)	B4
24V DC (only actuator version 1006, 1015, 2070)	C1
24V 50/60 Hz (only actuator version 1006, 2015)	C4
100-250V 50/60 Hz (only actuator version 2006, 2015)	O4
230V 50/60 Hz (only actuator version 2070)	O4

Functional module	Code
Standard OPEN/CLOSE control	A0
OPEN/CLOSE control with 2 additional potential-free limit switches	AE
OPEN/CLOSE control with potentiometer output	AP
Control module for external set value 0 - 10V DC	E1
Control module for external set value 0/4 - 20 mA	E2
OPEN/CLOSE control, not reversible	00
OPEN/CLOSE control, not reversible with 2 additional potential-free limit switches	0E
OPEN/CLOSE control, not reversible with potentiometer output	0P
For selection options see tables on page 3	

Actuator version	Code
Torque 6 Nm, operating time 4 sec; spur gear; DN 15-25; B1 / C1 / B4 / C4	1006
Torque 15 Nm, operating time 11 sec; planetary gear; B1 / C1	1015
Torque 6 Nm, operating time 4 sec; spur gear; DN 15-25; O4	2006
Torque 15 Nm, operating time 11 sec; planetary gear; DN 8-20; B4 / C4 / O4	2015
Torque 70 Nm, operating time 15 sec; ball bearing spindle; DN 8-20; B4 / C4 / O4	2070

Ball configuration (only with body type M)	Code
T-port	T
L-port	L

Order example	723	15	D	2	1	14	C1	A0	1006	T
Type	723									
Nominal size		15								
Body configuration (code)			D							
Connection (code)				2						
Valve body material (code)					1					
Seal material (code)						14				
Voltage/Frequency (code)							C1			
Functional module (code)								A0		
Actuator version (code)									1006	
Ball configuration (code)										T

Body dimensions - 2/2-way version [mm]

DN	LA			LB			LC			H1	øD	ød
	PVC-U	PP	PVDF	PVC-U	PP	PVDF	PVC-U	PP	PVDF			
15		65		103		102	71		73	28	54	20
20		70		115		114	77		82	34	65	25
25		78		128		126	84		90	38	73	32
32	88	85		146		141	94		100	44	86	40
40		93		164		164	102		117	50	98	50
50		111				199	123		144	61	122	63

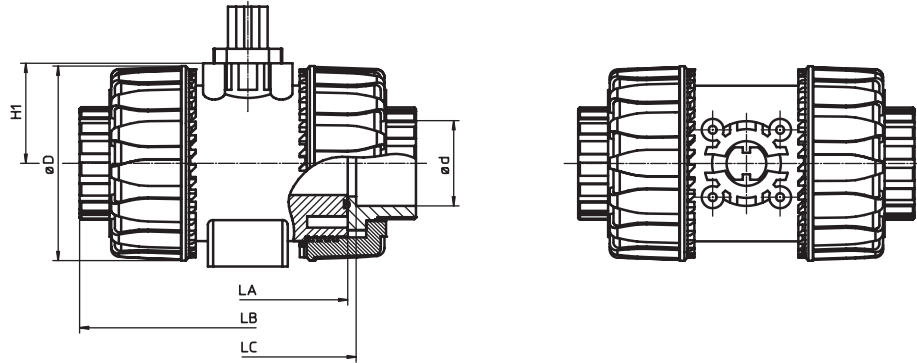

Body dimensions - 3/2-way version [mm]

DN	LA			LB			LC			LA1			LB1			LC1			H	H1	øD	ød
	PVC-U	PP	PVDF	PVC-U	PP	PVDF	PVC-U	PP	PVDF	PVC-U	PP	PVDF	PVC-U	PP	PVDF	PVC-U	PP	PVDF				
15	80			118.0	117.0		86.0	88.0		40.0			59.0	58.5	43.0	44.0			83.0	51.0	55	20
20	100			145.0	144.0		107.0	112.0		50.0			72.5	72.0	53.5	56.0			95.5	56.5	66	25
25	110			160.0	158.0		116.0	122.0		55.0			80.0	79.0	58.0	61.0			107.0	62.0	75	32
32	131			188.5	183.5		136.5	142.5		65.5			94.3	91.8	68.3	71.3			128.5	78.0	87	40
40	148			219.0	219.0		157.0	172.0		74.0			109.5	109.5	78.5	86.0			136.0	80.0	100	50
50	179			266.5			190.5	211.5		89.5			133.3		95.3	105.8			165.0	97.5	122	63

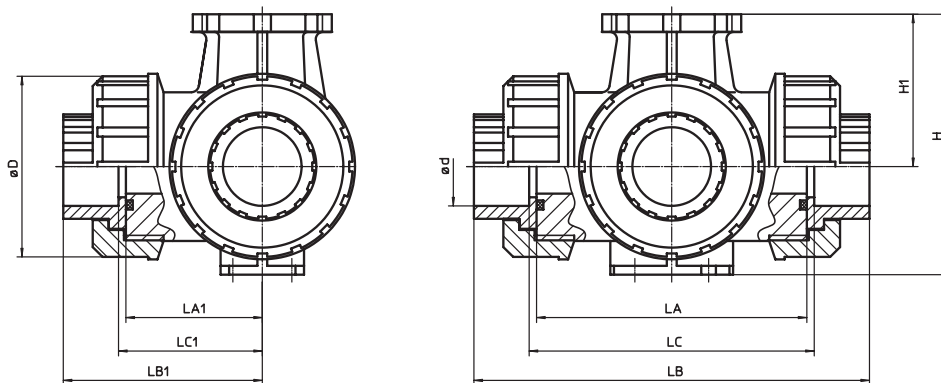

Connection dimensions - 3/2-way version [mm]

DN	ød4	ød1	ød3	ISO 5211
15	5.5	48	42	F04
20	7.0	57	50	F05
25	7.0	57	50	F05
32	9.5	79	70	F07
40	9.5	79	70	F07
50	9.5	79	70	F07

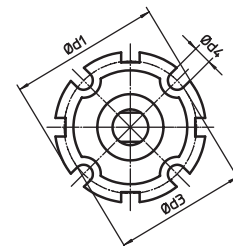

Actuator dimensions [mm]

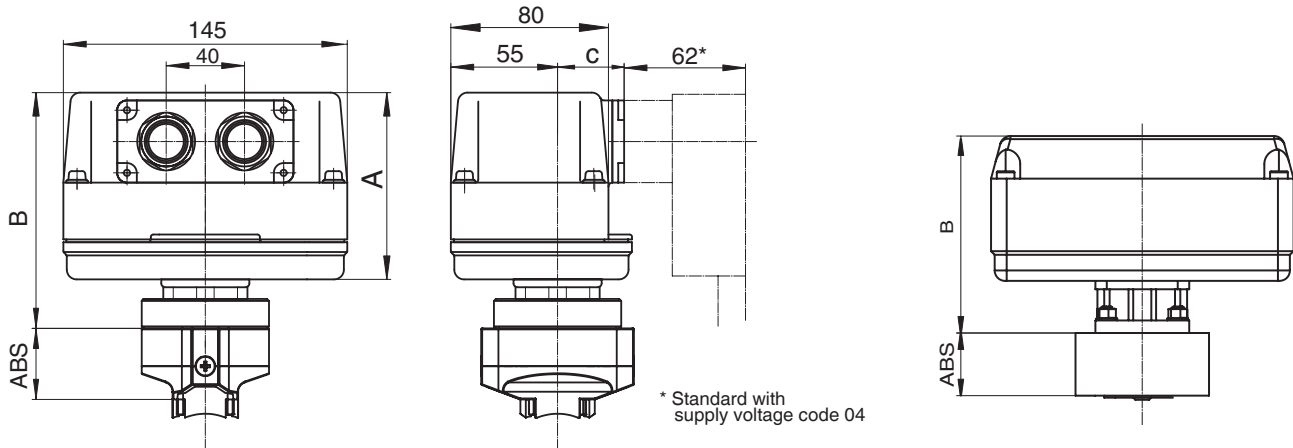

Actuator version	A	B
1006 - 1015	69	94
2006 - 2015	95	120
2070	see drawing	

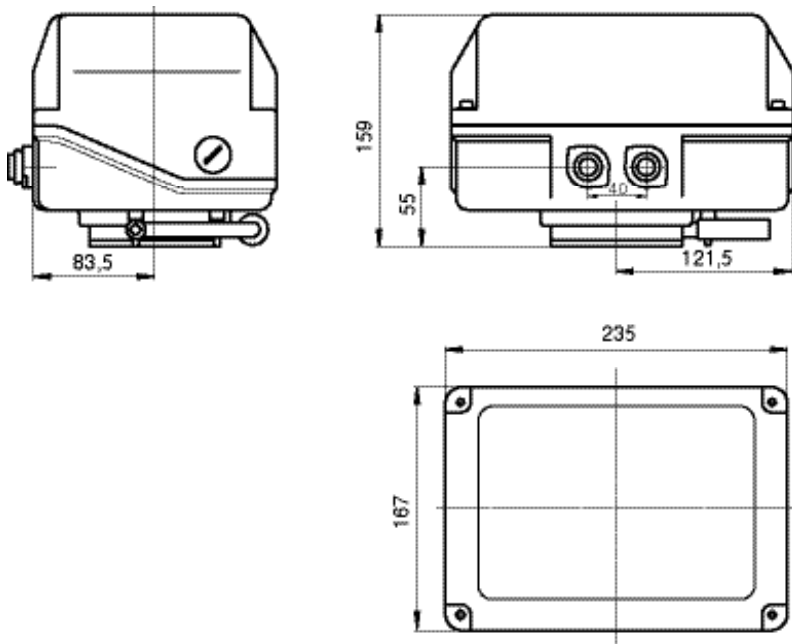

Mounting kit		
DN	ABS 2/2-way	ABS 3/2-way
15	30.0	28.0
20	35.5	30.0
25	35.5	30.0
32	47.0	22.5
40	47.0	22.5
50	52.5	16.0

Connection / wiring diagrams

Actuator version 1006, 1015 - 12V / 24V DC (A0 - OPEN/CLOSE control)

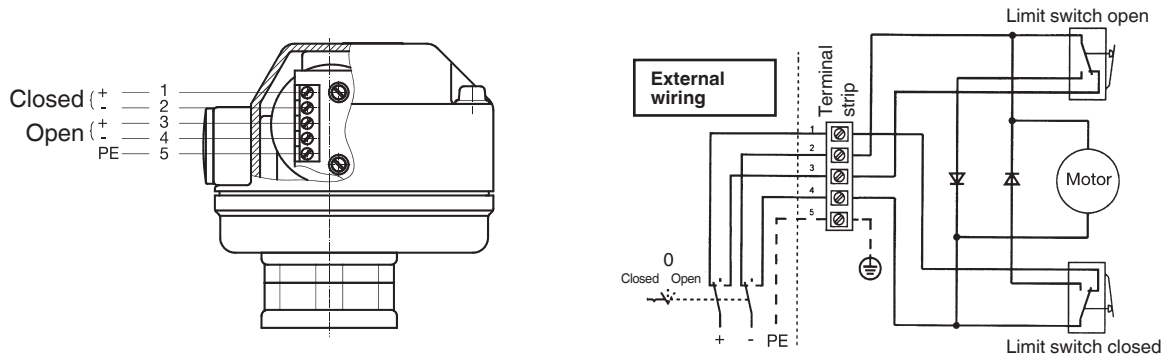

Terminals must not be bridged!
 If parallel connection of several actuators is required, the version with K-no. 6410 must be used.

Actuator version 1006, 1015 - 12V / 24V AC (A0 - OPEN-CLOSE control)

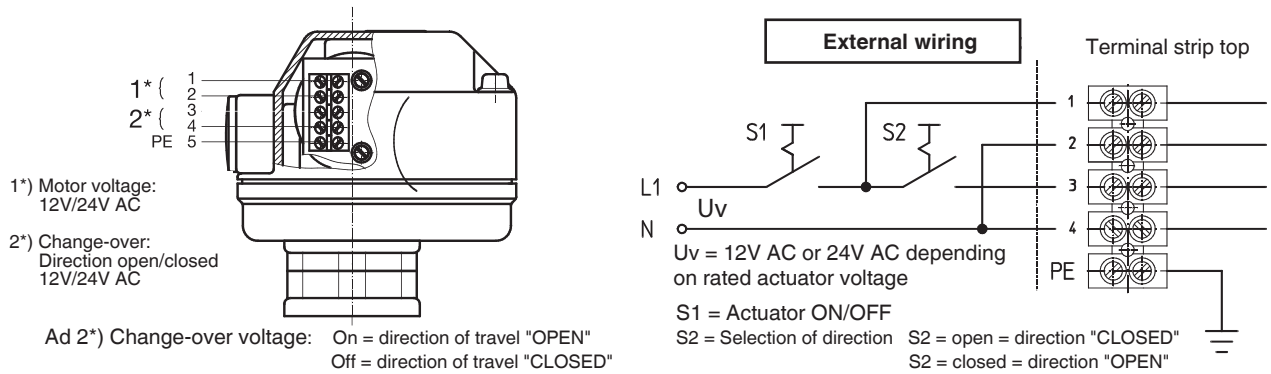

Actuator version 1006, 1015 - 12V / 24V DC (AE - 2 potential-free limit switches)

X1, X2 = Connector type Hirschmann N6RAM2931592-001

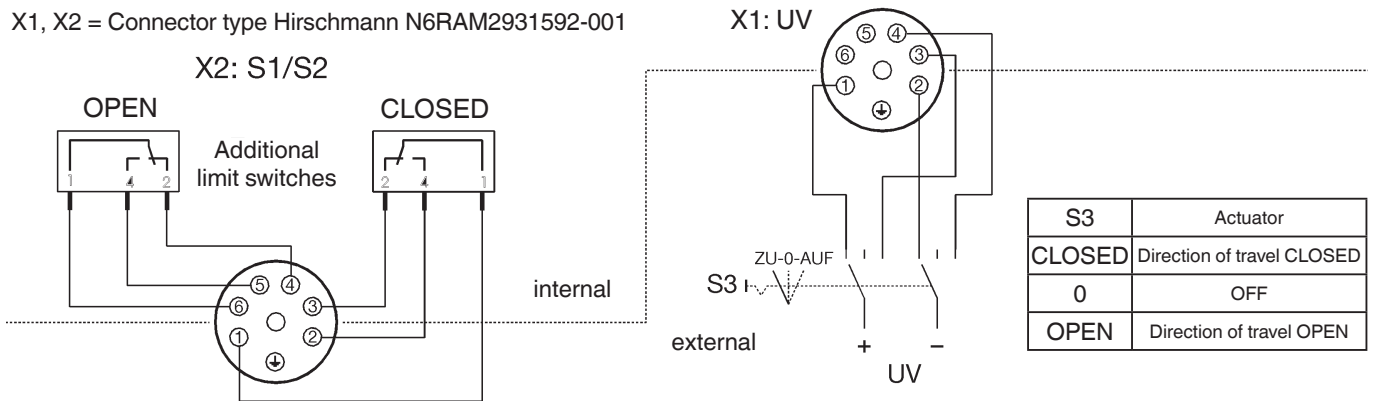

Connection / wiring diagrams

Actuator version 1006, 2015 - 12V / 24V AC (AE - 2 potential-free limit switches)

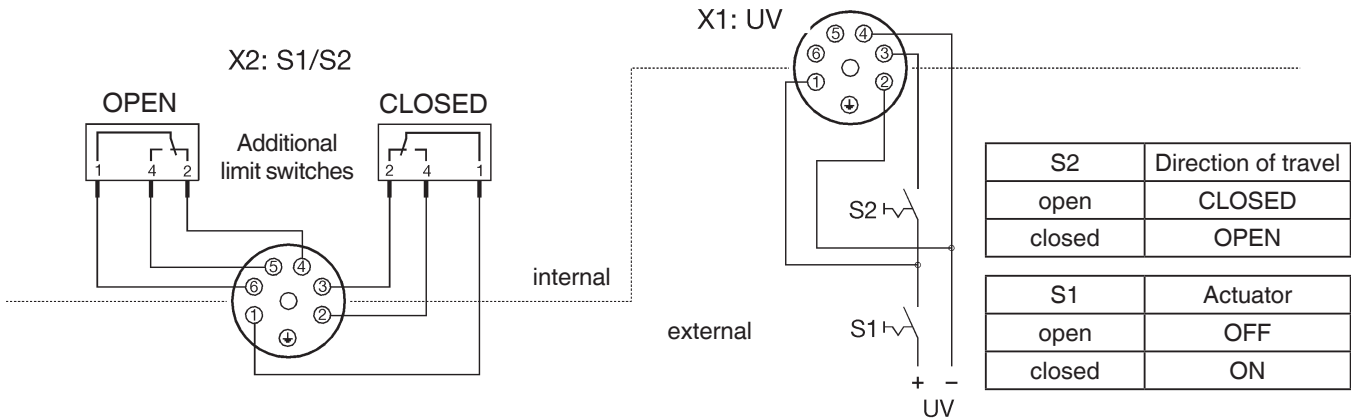

Actuator version 2006, 2015 - 100-250V AC (A0 - Open-Close control)

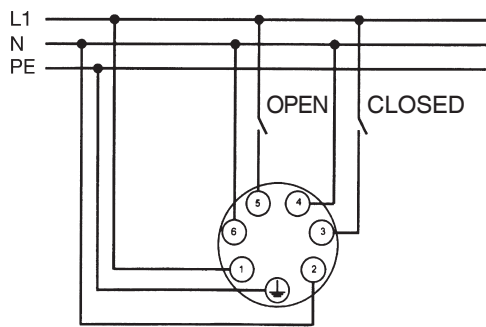

Pin	Signal name
1	L1 / L+, Supply voltage
2	N1 / L-, Supply voltage
3	L1 / L+, Direction of travel CLOSED
4	N / L-, Direction of travel CLOSED
5	L1 / L+, Direction of travel OPEN
6	N / L-, Direction of travel OPEN
Ⓧ	PE, Protective earth conductor

When the OPEN and CLOSED switches are operated simultaneously the actuator "CLOSES"

Pins 2, 4 and 6 can be joined in the connector plug

→ Advantage: 5-wire cable can be used.

No galvanic isolation of inputs!

Actuator version 2006, 2015 - 100-250V AC (AE - 2 potential-free limit switches)

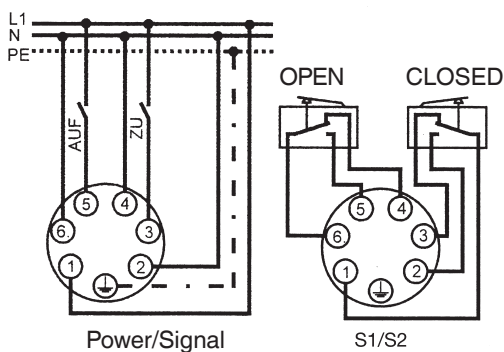

Pin	Signal name
1	L1 / L+, Supply voltage
2	N1 / L-, Supply voltage
3	L1 / L+, Direction of travel CLOSED
4	N / L-, Direction of travel CLOSED
5	L1 / L+, Direction of travel OPEN
6	N / L-, Direction of travel OPEN
Ⓧ	PE, Protective earth conductor

N / L-, signals in the unit are separated, potential assignment by customer

Pin	Signal name
1	S 1:1, Change-over contact limit switch CLOSED
2	S 1:4, Make contact limit switch CLOSED
3	S 1:2, Break contact limit switch CLOSED
4	S 2:2, Break contact limit switch OPEN
5	S 2:4, Make contact limit switch OPEN
6	S 2:1, Change-over contact limit switch OPEN
Ⓧ	PE, Protective earth conductor

Connection / wiring diagrams

Actuator version 2070 - 100-250V AC (A0 - OPEN-CLOSE control)

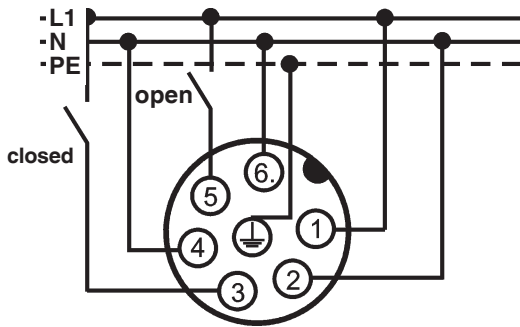

X 1: Power connector

Pin	Signal name
1	L1 / L+, Supply voltage
2	N1 / L-, Supply voltage
3	L1 / L+, Direction of travel CLOSED
4	N / L-, Direction of travel CLOSED
5	L1 / L+, Direction of travel OPEN
6	N / L-, Direction of travel OPEN
Ⓧ	PE, Protective earth conductor

When the OPEN and CLOSED switches are operated simultaneously the actuator "CLOSES"

Pins 2, 4 and 6 can be joined in the connector plug

→ Advantage: 5-wire cable can be used.

No galvanic isolation of inputs!

Actuator version 2070 - 100-250V AC (AE - 2 potential-free limit switches)

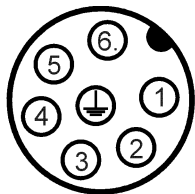

X 1: Power connector

N / L-, signals in the unit are separated. potential assignment by customer

Pin	Signal name
1	L1 / L+, Supply voltage
2	N1 / L-, Supply voltage
3	L1 / L+, Direction of travel CLOSED
4	N / L-, Direction of travel CLOSED
5	L1 / L+, Direction of travel OPEN
6	N / L-, Direction of travel OPEN
Ⓧ	PE, Protective earth conductor

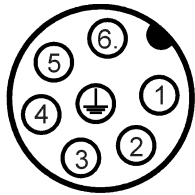

X 2: Connector S1/S2
(potential-free additional limit switches)

Pin	Signal name
1	S 1:1, Change-over contact limit switch CLOSED
2	S 1:4, Make contact limit switch CLOSED
3	S 1:2, Break contact limit switch CLOSED
4	S 2:2, Break contact limit switch OPEN
5	S 2:4, Make contact limit switch OPEN
6	S 2:1, Change-over contact limit switch OPEN
Ⓧ	PE, Protective earth conductor

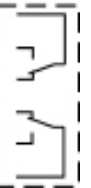

When the OPEN and CLOSED switches are operated simultaneously the actuator "CLOSES"

Actuator version 2070 (AP - potentiometer output)

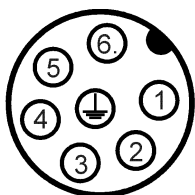

X 1: Power connector

N / L-, signals in the unit are separated, potential assignment by customer

Pin	Signal name
1	L1 / L+, Supply voltage
2	N1 / L-, Supply voltage
3	L1 / L+, Direction of travel CLOSED
4	N / L-, Direction of travel CLOSED
5	L1 / L+, Direction of travel OPEN
6	N / L-, Direction of travel OPEN
Ⓧ	PE, Protective earth conductor

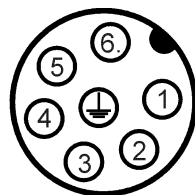

X 2: Connector S1/S2
(Rotary potentiometer for actual value feedback)

Pin	Signal name
1	n.c.
2	n.c.
3	n.c.
4	Us-, Actual value potentiometer signal voltage minus
5	Us-, Actual value potentiometer signal output
6	Us+, Actual value potentiometer signal voltage plus
Ⓧ	PE, Protective earth conductor

When the OPEN and CLOSED switches are operated simultaneously the actuator "CLOSES"

Connection / wiring diagrams

Actuator version 2070 (E2 - control module)

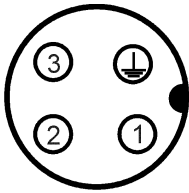

X 1: Power connector

Pin	Signal name
1	L1 / L+, Supply voltage
2	N1 / L-, Supply voltage
3	n.c.
⊕	PE, Protective earth conductor

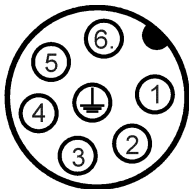

X 2: Signal connector

Pin	Signal name
1	n.a. (do not use)
2	n.a. (do not use)
3	I-, external set value 0/4-20mA
4	I+, external set value 0/4-20mA
5	n.c.
6	n.c.
⊕	PE, Protective earth conductor

Actuator version 2070 (E1 - control module)

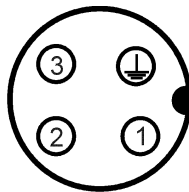

X 1: Power connector

Pin	Signal name
1	L1 / L+, Supply voltage
2	N1 / L-, Supply voltage
3	n.c.
⊕	PE, Protective earth conductor

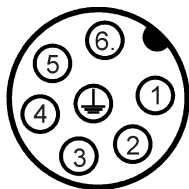

X 2: Signal connector

Pin	Signal name
1	n.a. (do not use)
2	n.a. (do not use)
3	U-, external set value 0-10V
4	U+, external set value 0-10V
5	n.c.
6	n.c.
⊕	PE, Protective earth conductor

Actuator version 2070 (00 - Open-Close control (relay version))

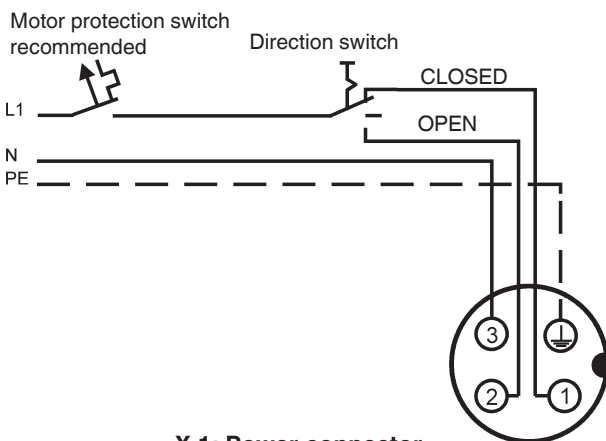

X 1: Power connector

Pin	Signal name
1	L1, Direction of travel CLOSED
2	L1, Direction of travel OPEN
3	N, Neutral conductor
⊕	PE, Protective earth conductor

Connection / wiring diagrams

Actuator version 2070 (0E - 2 potential-free limit switches (relay version))

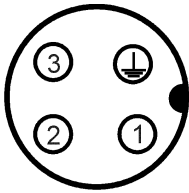

X 1: Power connector

Pin	Signal name
1	L1, Direction of travel CLOSED
2	L1, Direction of travel OPEN
3	N, Neutral conductor
⊕	PE, Protective earth conductor

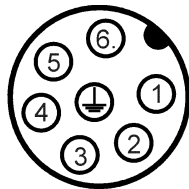

X 2: Connector S1/S2
(potential-free additional limit switches)

Pin	Signal name
1	S 1:1, Change-over contact limit switch CLOSED
2	S 1:4, Make contact limit switch CLOSED
3	S 1:2, Break contact limit switch CLOSED
4	S 2:2, Break contact limit switch OPEN
5	S 2:4, Make contact limit switch OPEN
6	S 2:1, Change-over contact limit switch OPEN
⊕	PE, Protective earth conductor

Actuator version 2070 (0P - potentiometer output (relay version))

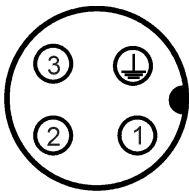

X 1: Power connector

Pin	Signal name
1	L1, Direction of travel CLOSED
2	L1, Direction of travel OPEN
3	N, Neutral conductor
⊕	PE, Protective earth conductor



X 2: Connector S1/S2
(Rotary potentiometer for actual value feedback)

Pin	Signal name
1	n.c.
2	n.c.
3	n.c.
4	Us-, Actual value potentiometer signal voltage minus
5	Us ₀ , Actual value potentiometer signal output
6	Us+, Actual value potentiometer signal voltage plus
⊕	PE, Protective earth conductor

Port positions

T - port

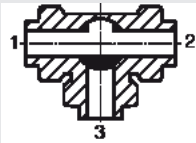
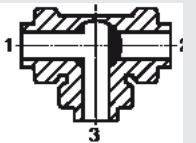
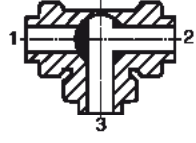
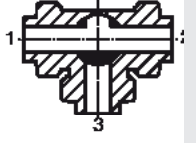
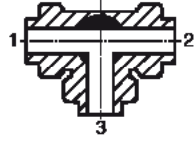
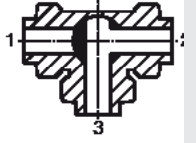
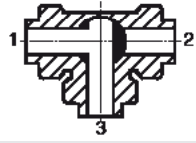
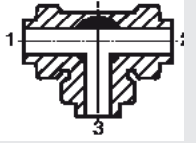
	End position "Closed"	End position "Open"
As supplied		
Optional port positions, can be user adjusted		
		
		

L - port

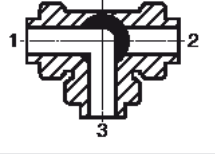
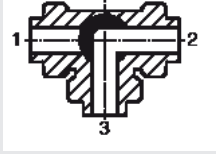
	
As supplied	Optional port positions, can be user adjusted

For further ball valves, accessories and other products, please see our Product Range catalogue and Price List.
Contact GEMÜ.



GEMÜ® VALVES, MEASUREMENT
AND CONTROL SYSTEMS